

## L9SP Sealing 1/2"~2"

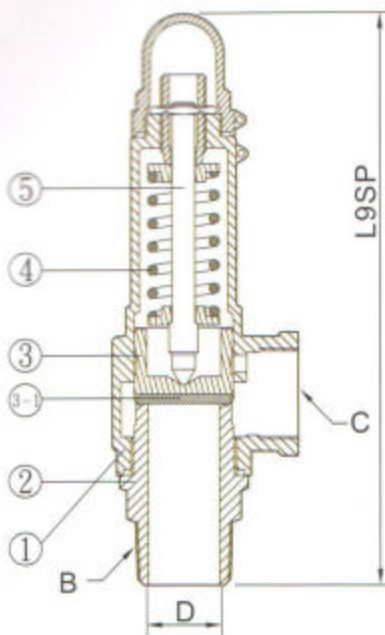

## L9-LSP Lever 1/2"~2"

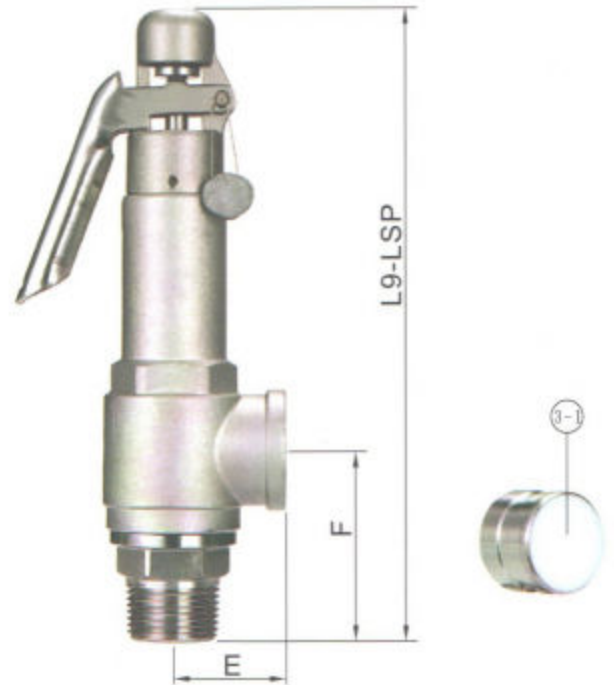

### Dimensions

(Sealing)

Unit:mm

(Lever)

Unit:mm

Item	Inlet	Outlet	Valve seat orifice	Lift	Wt. kg	Item	Wt. kg				
Size	L9SP	B	C	D	E	F	Size	L9-LSP	Wt. kg		
1/2"	142	1/2"	1/2"	13	29	49	0.52	0.5	1/2"	168	0.6
3/4"	164	3/4"	3/4"	19	36	55	0.76	0.7	3/4"	190	0.8
1"	200	1"	1"	25	40	67	1.00	1.2	1"	222	1.3
1-1/4"	232	1-1/4"	1-1/4"	32	50	79	1.28	2.0	1-1/4"	248	2.0
1-1/2"	256	1-1/2"	1-1/2"	38	54	86	1.52	2.6	1-1/2"	272	2.7
2"	282	2"	2"	50	66	96	2.00	4.3	2"	306	4.4

### General Material

NO.	Parts Name	Model	L9SP Sealing	L9-LSP Lever
1	Valve Body	CF8		
2	Valve Seat	SUS 304 or CF8		
3	Disc	SUS 304 or CF8		
3-1	Soft Seal	Teflon (PTFE)		
4	Spring	SUS 304		
5	Stem	SUS 304		
	Working Pressure		2~10 kgf/cm <sup>2</sup>	11~20 kgf/cm <sup>2</sup>
	Working Temp		-60 °C~196 °C	
	Working Fluid		Noncorrosive Gas \ Noncorrosive Liquid \ Corrosive Gas \ Corrosive Liquid \ Air \ Steam \ Water \ Oil	Noncorrosive Gas \ Corrosive Gas \ Air \ Steam

L9SP 2" L9-LSP 2" Working Pressure 11-20kgf/cm<sup>2</sup>, Valve Seat orifice(D) 40mm

Made in: Taiwan