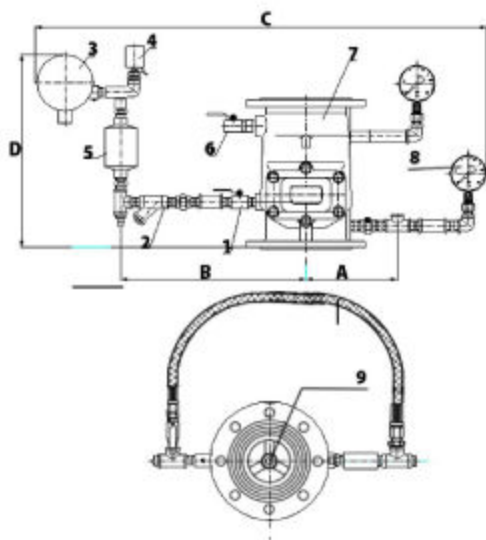

4. INSTALLATION

No.	Part Name	AL100	AL150	AL200
1	Ball valve	DN20	DN20	DN20
2	Y - Strainer	DN20	DN20	DN20
3	Gong bell	Ø200	Ø200	Ø200
4	Pressure Switch	ALPS16	ALPS16	ALPS16
5	Retard Chamber	Ø127	Ø127	Ø127
6	Ball valve	DN25	DN25	DN25
7	Main Check Valve	DN100	DN150	DN200
8	Pressure gauge	Y100	Y100	Y100
9	Compensator	DN20	DN20	DN20

No.	AL100	AL150	AL200
A	350	380	400
B	570	650	700
C	1030	1130	1200
D	620	670	690

- * Leakag test before installation, test pressure should be twice as much as the rated working pressure, asting for 5 minutes.
- * Alarm wet check valve should be installed vertically, the arrow mark should be in line with the direction of flow.
- * Clean out the pipeline.
- * Each drain of valve should be connected with drainage separately, keep free from obstruction.
- * Pressure switch installation should be convenient for viewing.